

A | B | C | D | E | F | G | H | I | J | K

1
2
3
4
5
6
7
8

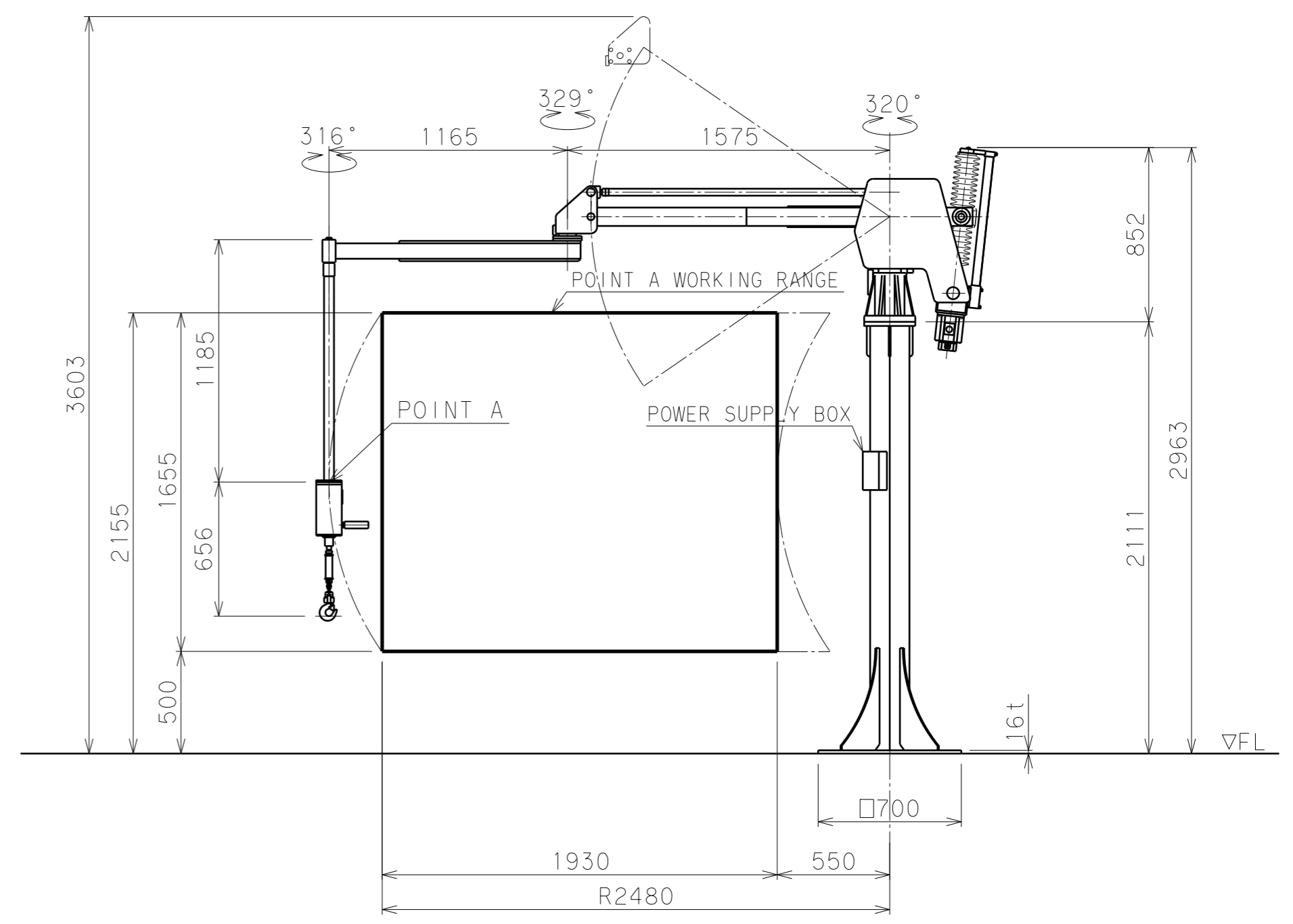
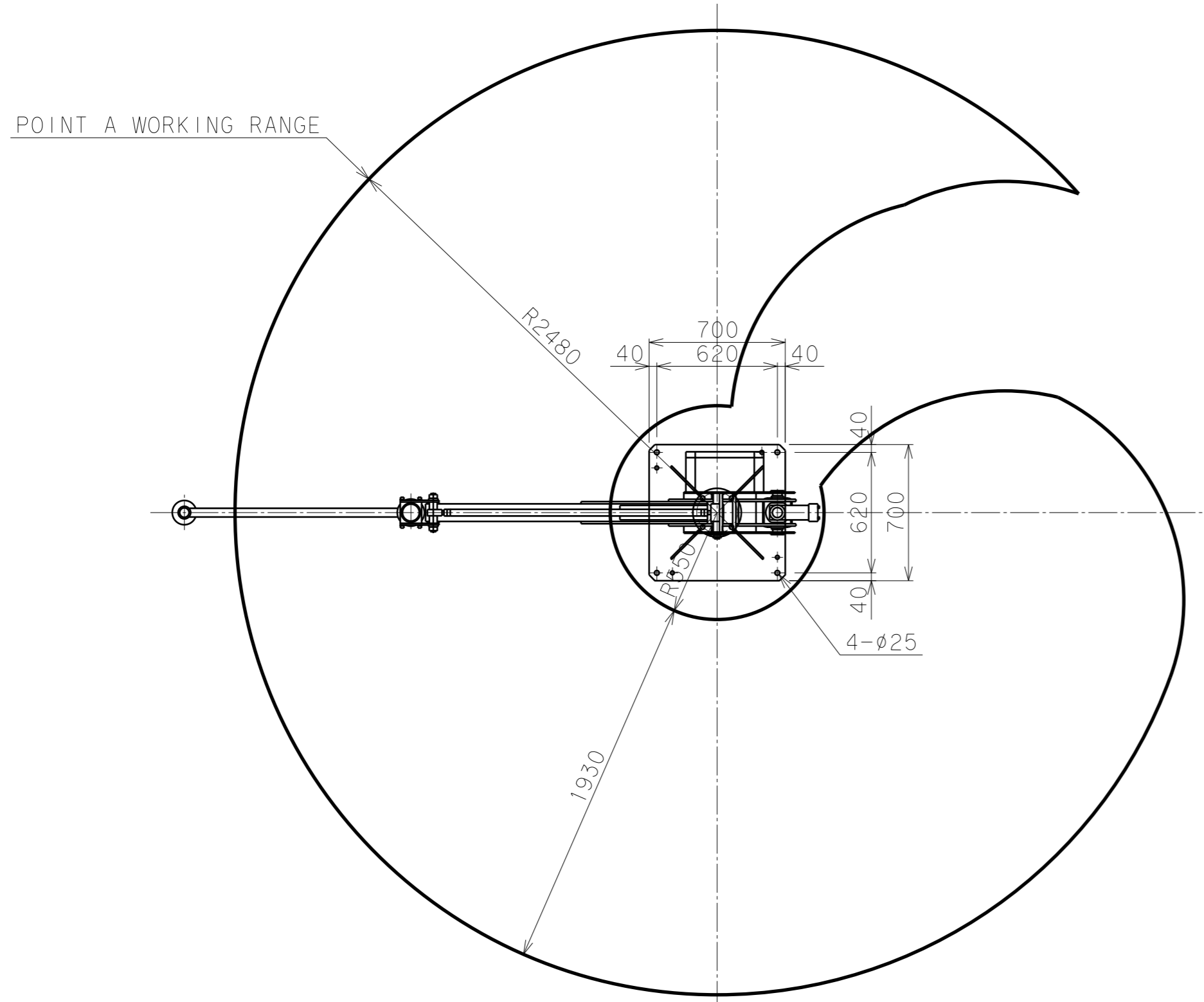

BALAMAN SPECIFICATIONS	
MODEL	BMi2S-75
MAX. LOAD	75kg (INCLUDING ATTACHMENT)
MAX. RADIUS	R2480 mm
HORIZONTAL STROKE	1930 mm
VERTICAL STROKE	1655 mm
MAX. WORKING HEIGHT	2155 mm
MAX. MACHINE HEIGHT	3603 mm
LIFTING SPEED	600 mm/s
POWER SUPPLY	Three-Phase AC200/220V±10% 50/60Hz 2.3kVA
CONTROL SYSTEM	CRANE AND BALANCE
COATING	MAIN BODY & BASE F-58 (BLUE) G-63 (SILVER) ATTCHMENT 10R5.5/14.5 (MUNSELL No.)
MAIN UNIT MASS	APPROX. 215kg
BASE UNIT MASS	APPROX. 190kg
REMARKS	ACCESSORIES: POWER SUPPLY BOX