

A | B | C | D | E | F | G | H | I | J | K

1  
2  
3  
4  
5  
6  
7  
8

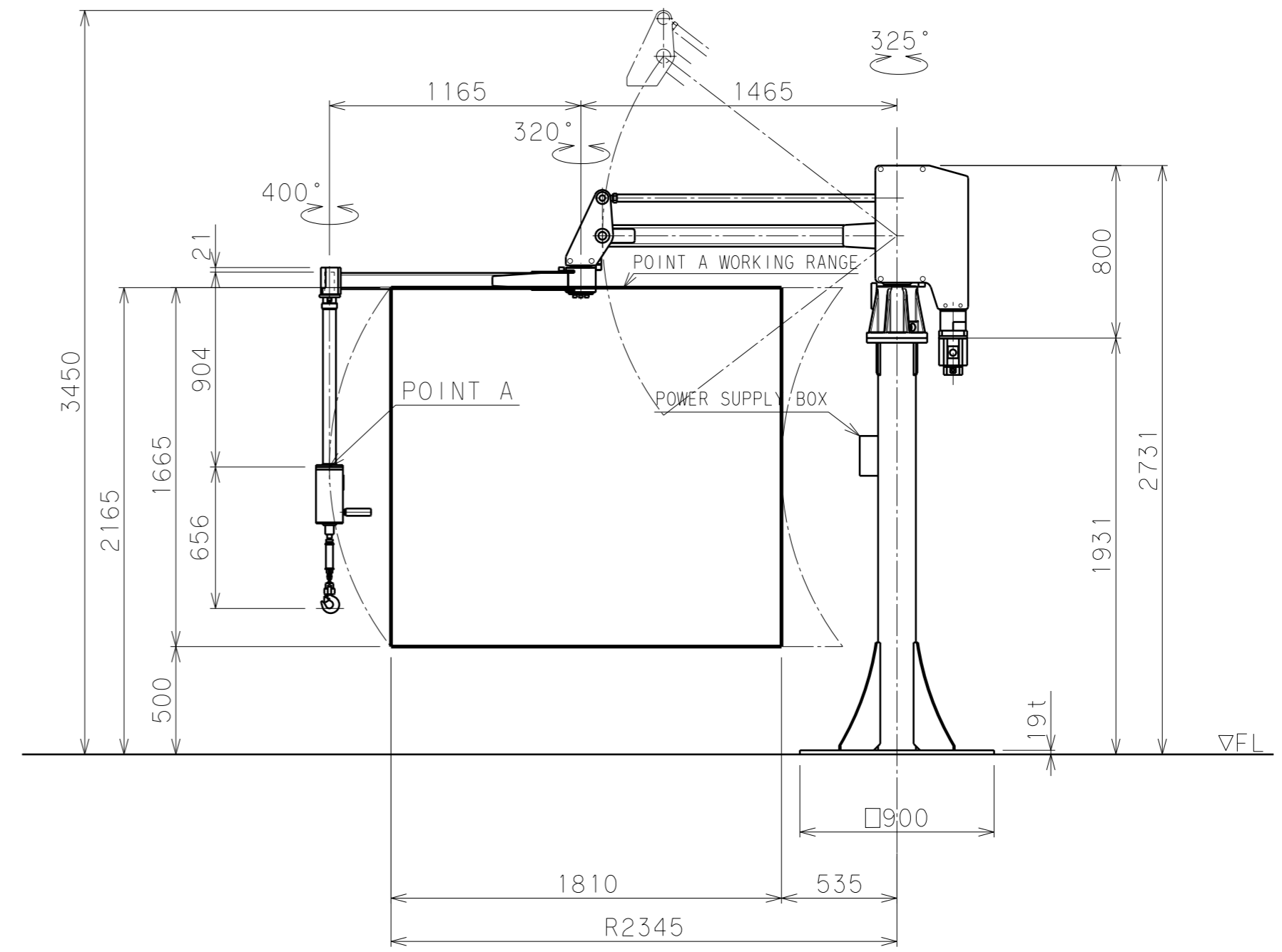
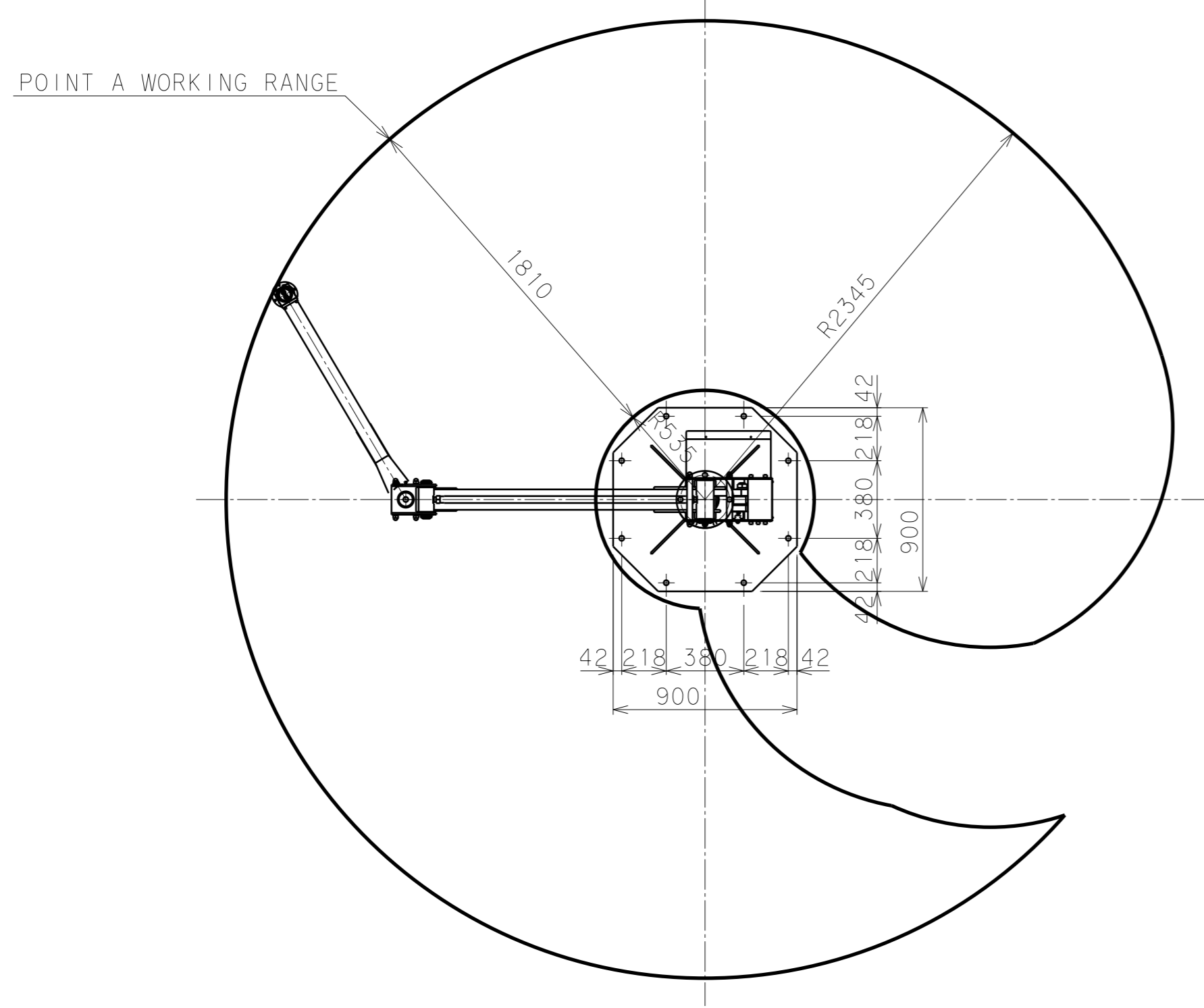

BALAMAN SPECIFICATIONS	
MODEL	Bmi2S-150
MAX. LOAD	150kg (INCLUDING ATTACHMENT)
MAX. RADIUS	R2345 mm
HORIZONTAL STROKE	1810 mm
VERTICAL STROKE	1665 mm
MAX. WORKING HEIGHT	2165 mm
MAX. MACHINE HEIGHT	3450 mm
LIFTING SPEED	400 mm/s
POWER SUPPLY	Three-Phase AC200/220V±10% 50/60Hz 2.5kVA
CONTROL SYSTEM	CRANE AND BALANCE
COATING	MAIN BODY & BASE F-58 (BLUE) G-63 (SILVER) ATTCHMENT 10R5.5/14.5 (MUNSELL No.)
MAIN UNIT MASS	APPROX. 240kg
BASE UNIT MASS	APPROX. 250kg
REMARKS	ACCESSORIES: POWER SUPPLY BOX