

A | B | C | D | E | F | G | H | I | J | K

1
2
3
4
5
6
7
8

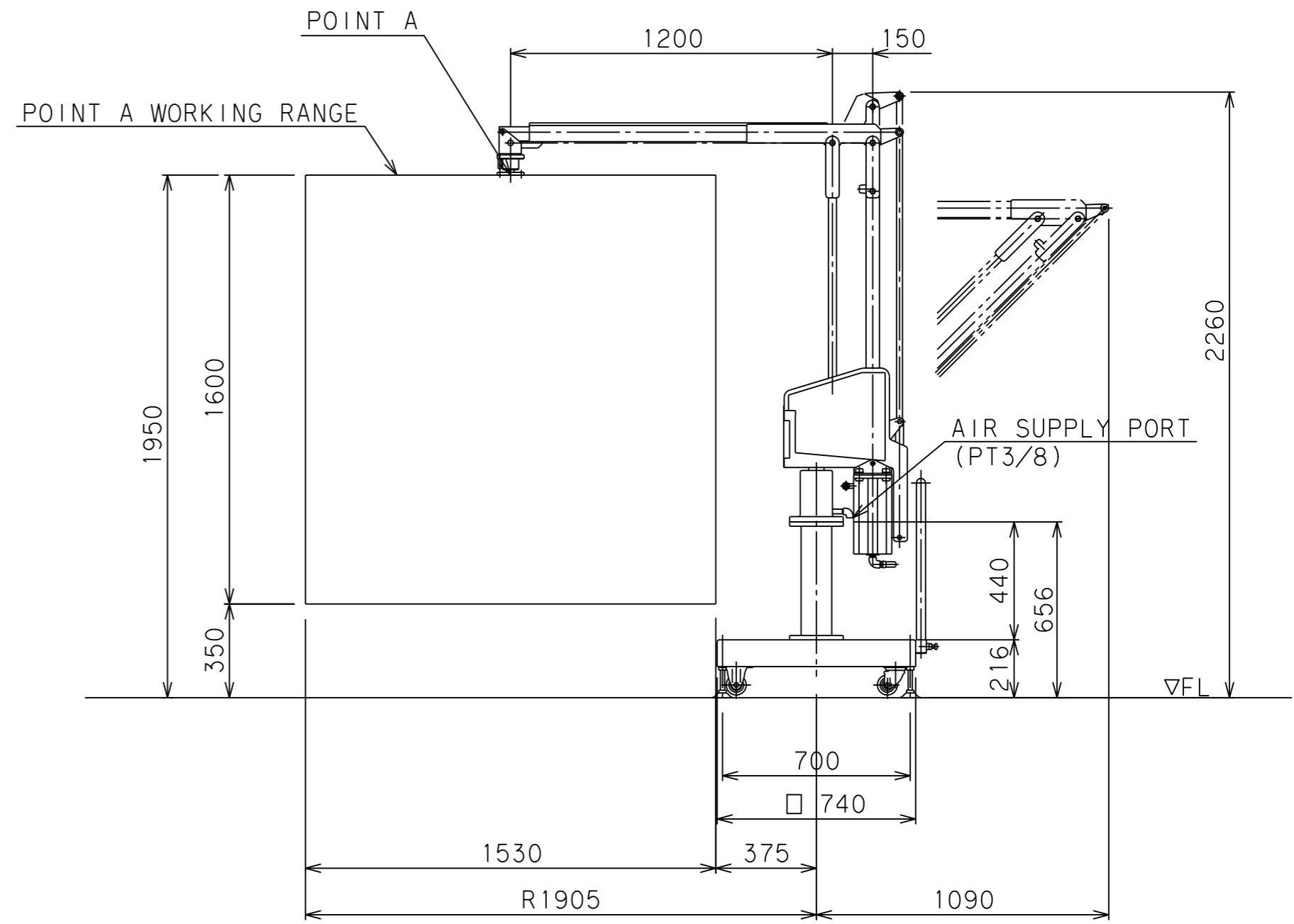
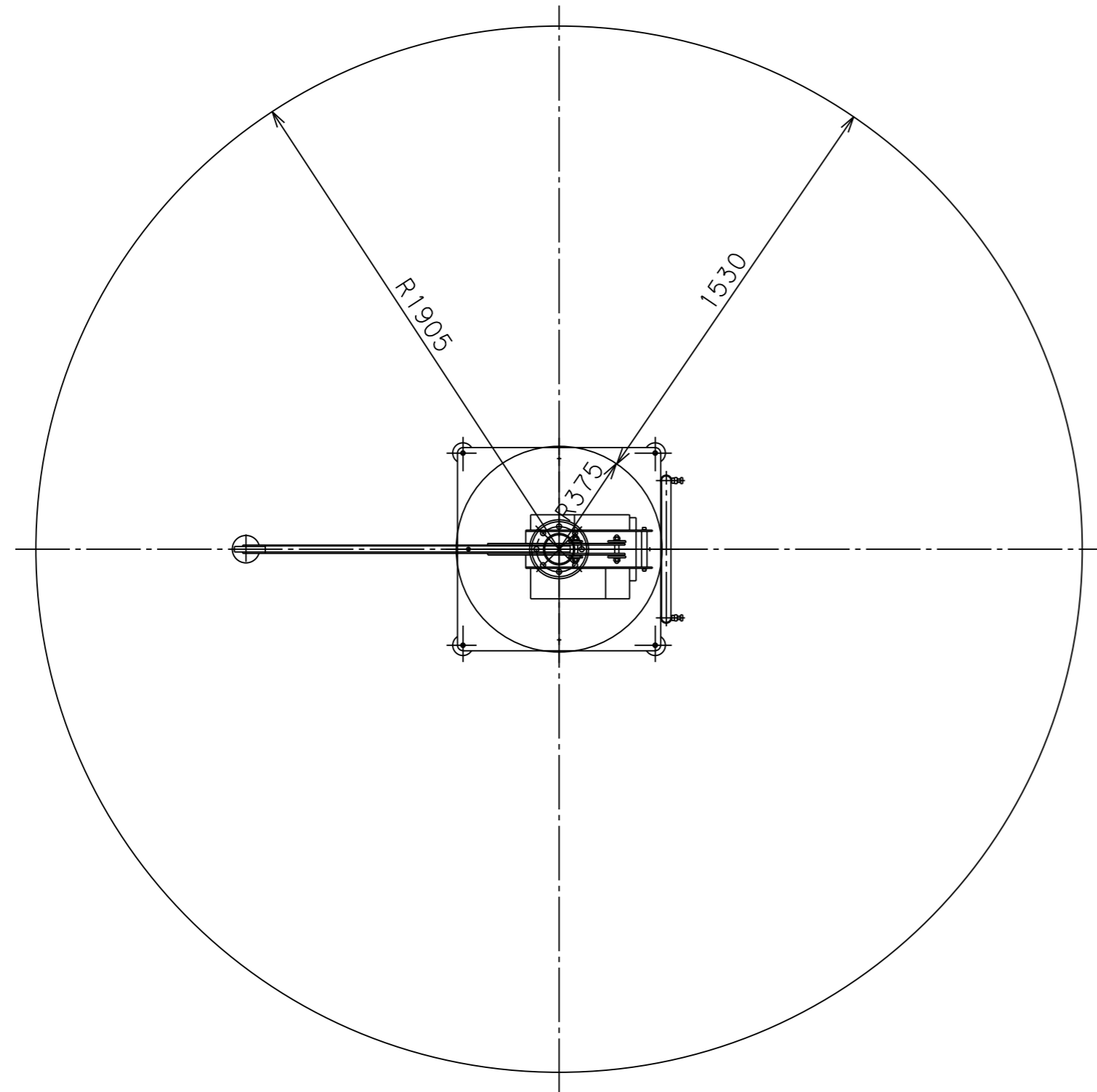

BALAMAN SPECIFICATIONS	
MODEL	BMG-50W
MAX. LOAD	50kg (INCLUDING ATTACHMENT)
MAX. RADIUS	R1905 mm
HORIZONTAL STROKE	1530 mm
VERTICAL STROKE	1600 mm
MAX. WORKING HEIGHT	1950 mm
MAX. MACHINE HEIGHT	2260 mm
CONTROL METHOD	
AIR SUPPLY	0.49 MPaG
AIR CONSUMPTION	75NL/min (10 SEC CYCLE)
COATING	MAIN BODY & BASE 5.5PB4.7/9.4 (MUNSELL NO.) ATTACHMENT 10R5.5/14.5 (MUNSELL No.)
MAIN UNIT MASS	Approx. 135kg
BASE MASS	Approx. 450kg
REMARKS	PRESSURE REDUCE SET